

*The need to move fluids from one place to another has created a vast universe of pumping equipment of various shapes, sizes, configurations, and designs. As discussed in Power & Fluids, Volume 7/No. 3, "Centrifugal Pumps as Hydraulic Turbines," most centrifugal pumps can be run in reverse as hydraulic turbines. As a result, pumping equipment needed to satisfy the requirements of small-hydropower customers is readily available, unlike conventional turbines.*

*Besides being readily available, pumps are also less complex than conventional turbines, more flexible—they can be mounted vertically or horizontally, wet pit, dry pit,*

## **Pumps as turbines: Systems and applications.**

**By L. Shafer**

*and even submersible—can attain similar efficiencies, and, of prime importance to the small-site owner, are normally less expensive. Spare parts availability and shorter production lead times are also advantages for pumps.*

*Also discussed in a previous issue of Power & Fluids (Volume 8/No. 1, "Comparing Control Systems for Hydraulic Turbines") were two kinds of generators, induction and synchronous, and their basic operating characteristics when employed in co-generation-type applications. This article expands on these two previous discussions with a detailed examination of some typical systems encountered in the application of pumps as hydraulic turbines.*

*Larry Shafer is marketing manager, hydropower and water supply, at Worthington's Taneytown, Maryland, operation.*

**A**n understanding of the specialized vocabulary and mathematical formulas which are applicable to pump applications as turbines will be useful to our discussion. Tables I and II on page 18 provides a glossary and a listing of relevant formulas.

### **Typical installations.**

The first typical installation we will examine, as shown in Figure 1, is a wet-pit propeller or mixed-flow pump as a turbine. These units are generally low head, less than 75 feet, and high capacity, up to about 225 cfs. They lend themselves to small dams or naturally falling water where the turbine can be mounted directly over the tailwater in a wet-pit configuration. The unit can be vertically mounted with a vertical shaft and direct-coupled generator, or it can be a horizontally mounted, dry-pit design with intake and exhaust pipe connections.

In the 75- to 200-foot range are the Francis-type pumps. As shown in Figure 2, these hydraulic turbines are used at high dams or similar installations and can handle capacities up to 110 cfs. Although this is a dry-pit installation, the vertical mounting allows for the use of vertical shafting to raise the generator well above any possible flood level. In addition to the elbow exhaust vertical mounting, this turbine can be vertically designed with bottom discharge, or horizontally designed.

Centrifugal pumps are very well suited for hydroturbine applications in the 200- to 500-foot head range. Figure 3 illustrates a horizontal split-case pump which has been installed in parallel with a pressure-reducing valve in a pipeline to recover wasted energy. Horizontal, dry-pit, split-case pumps make excellent turbines for these applications because the intake and exhaust pipe connections are on the same centerline. The potential for a hydraulic turbine of this type

exists anywhere a pipeline contains a pressure-reducing valve.

### Single vs. multiple hydraulic turbine applications.

The normal constant-speed hydraulic turbine head/capacity curve has a steep, positive slope; that is, at low flows the head is low, and to achieve higher flows, the head must be increased. This is suitable for many applications. For example, if a hydro developer has a dam site and wishes maximum capacity at the high-dam level with decreased capacity as the dam level is lowered, the normal single-pump installation is ideal. The curve in Figure 4 shows how a typical system of this type would operate.

Hydraulic turbine systems that have a broad range of flow requirements may require more control equipment; however, it does not have to be complicated. A simple timer may be incorporated into the control to automatically shut down the hydraulic turbine after a preset time, which can be varied, based on the amount of flow to be passed on a given day.

Multiple hydraulic turbines may be necessary if a greater flow range is required. For example, a system with a minimum flow of 10 cfs, a maximum flow of 60 cfs, and using three hydroturbine units rated at 10, 20 and 30 cfs would be able to handle the total flow in steps of 10, 20, 30, 40, 50, and 60 cfs very easily.

### Variable flow applications.

There are situations where stepless, infinitely variable flow is required. A common application for a hydraulic turbine of this type would be as a pressure-reduction machine in a municipal water supply. Water may flow down from a mountain reservoir with a relatively constant pressure, but the flow will vary during the day as a function of the resident's requirements.

A pressure-reducing valve (PRV)

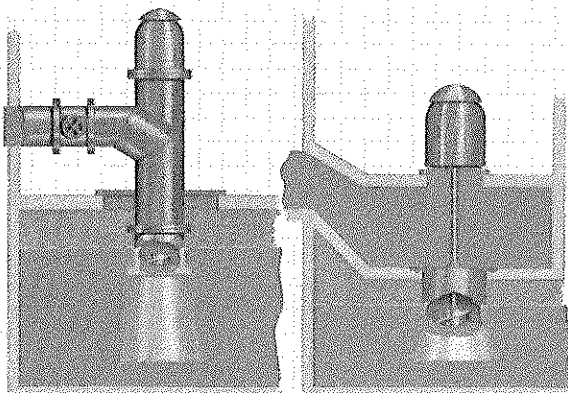

**Figure 1—Vertical propeller pump/turbine for wet-pit application.**

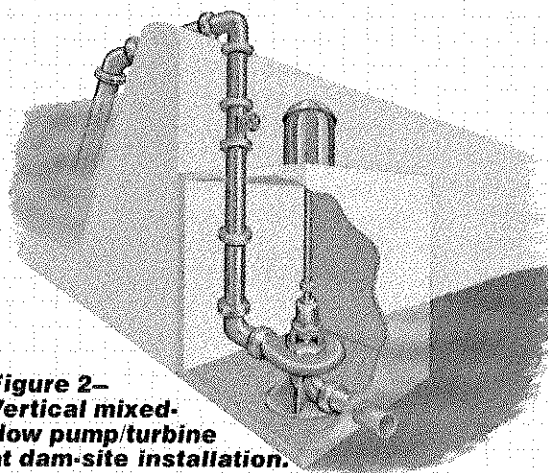

**Figure 2—Vertical mixed-flow pump/turbine at dam-site installation.**

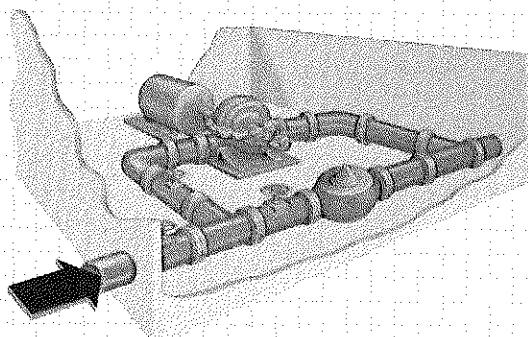

**Figure 3—Horizontal split-case pump/turbine installed in parallel with a pipeline pressure-reducing valve.**

with flow control most likely exists in the pipeline to break down the pressure while controlling the flow. A hydraulic turbine should be installed in parallel with the valve, as previously shown in Figure 3, to recover the lost energy. A system head curve and a hydraulic turbine curve for this kind of application are shown in Figure 5.

At a flow of 41 cfs, the hydraulic turbine curve and system curve match exactly at the turbine best efficiency point. However, in order to reduce the capacity to below 41 cfs, the hydraulic turbine control valve must be partially closed, which makes up the difference in head between the system curve and the hydraulic turbine curve. To achieve flows above 41 cfs, the hydraulic turbine control valve is opened completely, and the existing PRV is opened slightly to act as a bypass valve.

The system just described is quite sufficient for many applications. However, note that because some head is still wasted in valving, the system efficiency is not optimum. To improve the efficiency, multiple hydraulic turbines could be used. Figures 6 and 7 demonstrate how a system of this type would operate.

At flows between 24 and 27 cfs, only Turbine 1 would be running, and its control valve would be partially open. At flows between 27 and 31 cfs, Turbine No. 1's control valve would be completely open, and some of the flow would bypass into Turbine No. 2. When Turbine No. 2 reached synchronous speed, it would be also started up. This sequencing would continue until full flow was achieved. Note the improvement in the system efficiency with the multiple hydraulic turbine configuration.

**Variable head applications.**

Systems with very steep or even vertical system head curves lend themselves to variable-speed

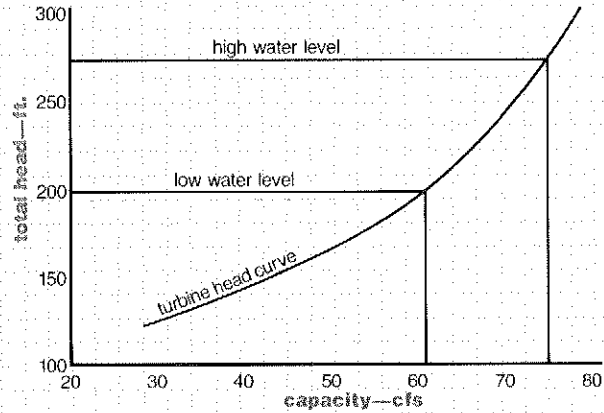

**Figure 4—Constant-speed turbine with variable head and flow relationships.**

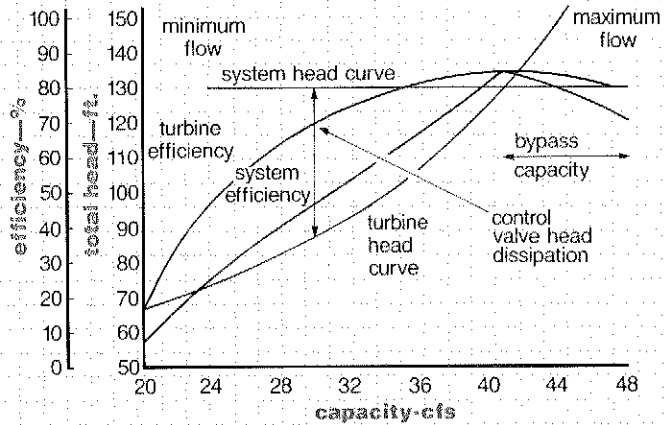

**Figure 5—Variable-flow system with constant head utilizing a single constant-speed turbine.**

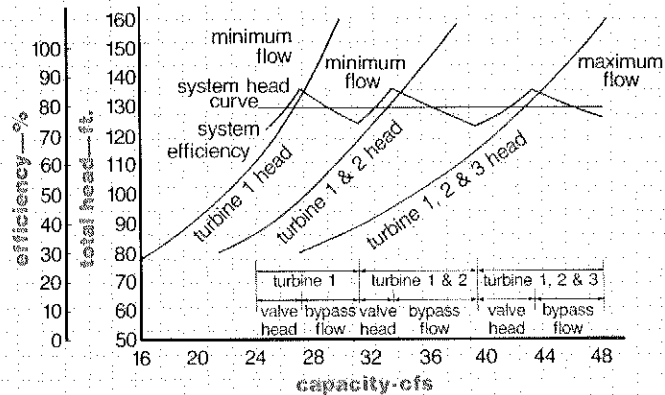

**Figure 6—Variable-flow system with constant head utilizing multiple constant-speed turbines.**

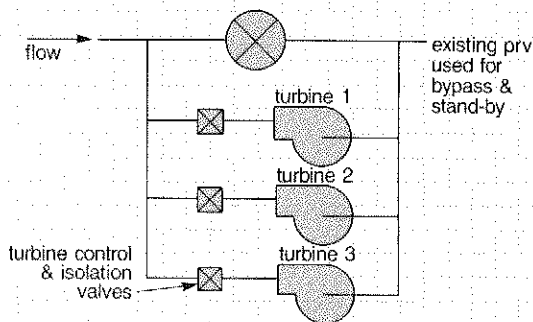

**Figure 7—Schematic diagram for a multiple turbine, variable flow system.**

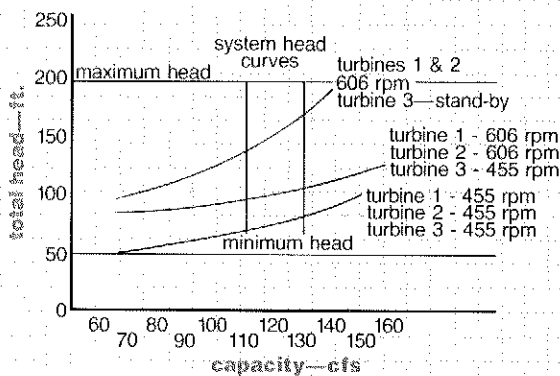

**Figure 8—Variable head system utilizing multiple, two-speed turbines.**

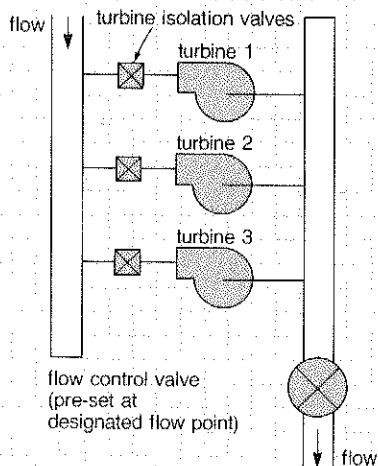

**Figure 9—Schematic diagram for multiple, two-speed turbine, variable head system.**

hydraulic turbines. As an example, consider a dam with a short enough head race so that the friction losses are minimized. The system curve would be essentially vertical, as shown in Figure 8. Conditions at the site require a constant flow release at any given head condition, while retaining the ability to change the flow from time to time. This is best accomplished with a system as shown schematically in Figure 9.

If the application is at an existing site, the flow control valve may already be in place, and will most likely be able to operate in series with the hydraulic turbines, each of which is connected to a two-speed generator. The speed of the generator would be controlled either manually or automatically, based on the upstream pressure and the point where the hydraulic turbine curve crosses the system curve. The flow control valve would then break down the differential pressure between the system head and the hydraulic turbine curve to maintain a constant flow.

This variable-speed-type system works best only with very steep system curves, but not as well with flat or horizontal curves as shown previously in Figure 6.

### **Flexibility the key.**

It has been demonstrated that with a little imagination, pumps applied as hydraulic turbines can be made to perform easily enough within numerous system requirements. Each particular site must be evaluated to determine the most beneficial operating system to optimize the potential payback. Doubtlessly, readers of this article will be able to devise variations of the schemes presented here based on the requirements of the site and the flexibility of using pumps as hydraulic turbines.

## Turbine Nomenclature

<b>head water</b>	Source of water to power the turbine.
<b>head race</b>	Open channel or enclosed pipeline (penstock) to deliver the head water to the turbine inlet.
<b>runner</b>	The impeller or propeller in a pump. Some axial flow or "tube" type conventional turbine runners may have adjustable runner blades to match changes in the available flow.
<b>draft tube</b>	Tapered exhaust section from the turbine, utilized to minimize exhaust losses and improve overall turbine efficiency.
<b>tailrace</b>	Exhaust channel or pipeline to return flow to the tailwater.
<b>tailwater</b>	Exhaust water from turbine.
<b>treh</b>	Total required exhaust head. The amount of back pressure the turbine requires to prevent cavitation. Similar to npshr in a pump.
<b>taeh</b>	Total available exhaust head. The amount of back pressure available at the site. Similar to npsha in a pump.
<b>cfs</b>	Cubic feet per second (1 cfs = 448.8 gpm)
<b>wicket gates</b>	Adjustable "diffusers" in conventional radial flow or "Francis" turbines which change the angle of flow into the runner as a function of the capacity to improve efficiency. This design has not yet been applied to reverse running pumps because it is extremely expensive and complicated to operate.
<b>flow duration curve</b>	A plot of flow versus percent of time the flow is achieved. Useful in determining the number of turbines required to match the flow conditions at the site.

## Turbine Formulas

### Turbine output:

$$KW = \frac{Q \times H \times E}{5310}$$

where Q = turbine capacity, gpm  
H = turbine head, feet  
E = turbine efficiency

or

$$KW = \frac{Q \times H \times E}{11.83}$$

where Q = turbine capacity, cfs  
H = turbine head, feet  
E = turbine efficiency

### Affinity laws:

$$\frac{N_1}{N_2} = \frac{Q_1}{Q_2} = \sqrt{\frac{H_1}{H_2}}$$

where N = speed  
Q = capacity  
H = head  
1 = speed no. 1  
2 = speed no. 2

### Runaway Speed:

$$N_r = N \sqrt{H/H_z}$$

where  $N_r$  = runaway speed  
N = normal speed  
H = head at which runaway is calculated  
 $H_z$  = head at zero torque, (at zero efficiency pt.)